



ClearCut²⁹

High-brightness, Low BPP

Materials Processing Laser

DESCRIPTION

The High-brightness editions of the Power Technology ClearCut Laser Engine are engineered for the demanding needs of precision precious metals processing and fabrication that require a low Beam Parameter Product (BPP). The laser's unique wavelength of 450 nm is optimized for maximum absorption of copper, silver and gold. This unique optimization makes the ClearCut up to 20 times faster and more efficient compared to traditional cutting lasers at 1064 nm. The ClearCut provides excellent wall-plug efficiency and lower maintenance costs. The ClearCut Laser Engine offers easy integration thanks to its air cooled architecture. No external liquid cooling is required.

Perfectly engineered for precision uses such as watchmaking and jewelry applications, the ClearCut Laser Engine will reduce your fabrication times, costs, and mistakes. The 113 to 365 um fiber output gives you precise control over the laser, making it ideal for your most demanding applications.

Available in power outputs from 110 Watts to more than 700 Watts, contact us today for a quote that fits your custom requirements. Don't buy on the shelf products when Power Technology can configure the exact ClearCut Laser Engine for your application.

APPLICATIONS

- Jewelry
- Watchmaking
- Cutting
- Medical
- Optical Pumping

FEATURES & BENEFITS

- Multiple power options
- Perfect wavelength for maximum absorption
- Air-cooled design

SPECIFICATIONS

ClearCut	110	300	400	700
Wavelength (nm)	445	445	445	445
Output Power (W)	110	300	400	700
Output Fiber Diameter (µm)	113	260	260	365
Numeric Aperture	.15	.15	.15	.15
Fiber Length (m)	5	5	5	5
Fiber Connector (SMA)	QBH	QBH	QBH	QBH
Supply Voltage (VAC)	110/240	110/240	110/240	110/240
Operating Temperature (C)	10-30	10-30	10-30	10-30
Rack Mount Units (Standard 19")	3	3	3	3
Rack Depth (Inches)	26	26	26	26
Power Density (MW/cm ²)	1.097	.565	.753	.669
Brightness (MW/cm ² -str)	15.40	7.93	10.58	9.39
BPP (mm-mrad)	8.44	19.43	19.43	27.27

MECHANICAL DRAWINGS

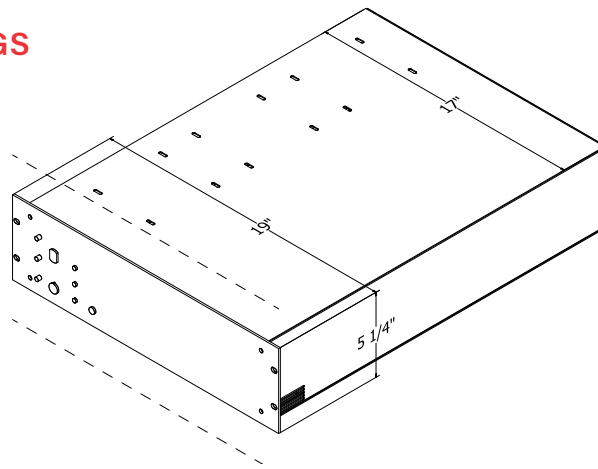

SAFETY WARNINGS

LASER RADIATION
AVOID EYE OR SKIN EXPOSURE TO
DIRECT OR SCATTERED RADIATION
CLASS 4 LASER PRODUCT

COMPLIANT & REGISTERED

